

ENGLISH FOR AIRCRAFT

A new course specifically
for teaching English to aircraft maintenance staff.

TECHNICAL ENGLISH

Aircraft mechanics, technicians and engineers have to read :

- Aircraft and Component Maintenance Manuals
- Service Bulletins
- Structural Repair Manuals
- Illustrated Parts Catalogs
- Airworthiness Directives
- Service Information Letters
- Trouble-shooting Manuals
- technical reports
- logbooks
- telexes, and so on.



In order to ensure standards of efficiency and safety, these documents have to be interpreted quickly and accurately.

English for Aircraft is designed to make this possible.

**Designed for a combination
of work in the classroom and self-access.**

THE ENGLISH THAT TECHNICIANS NEED TO

1. documentation handbook

● The *Documentation Handbook* follows a regular progression and assumes an initial minimum "pre-intermediate" or "false beginner" level.

It proceeds from an analysis of the structures of aeronautical English to a simple, pragmatic coverage of the syntax, grammar and terminology in use today.

Each of the 26 modules has a short explanatory **Notes** section with authentic examples and illustrations, followed by a series of exercises.

A variety of exercises practise what has been presented in the module.

CONTENTS	
Foreword	6
PART ONE	
Introduction	8
A. Word order	10
B. Location	15
C. Verb forms	19
D. Instructional procedure	21
E. Basic sentence structure	26
F. Word endings	36
G. Prefixes, suffixes	42
Review One	46
PART TWO	
Introduction	48
H. Physical characteristics	50
I. Dimensions	55
J. Purpose	59
K. Conjunctions	64
L. Actions	68
M. Possibility, probability, necessity	74
Review Two	78
PART THREE	
Introduction	100
Comparisons	105

26 modules, from A to Z.

Review sections provide the opportunity for consolidation and testing.

Authentic, concise examples.

CONNECTION (join, attach, link, link up)
The ABC is connected to the flight system.

For the last 40 (forty) actions, the verb is blank in the example. Fill in the blank with the correct form of the verb, i.e. the imperative, the infinitive ("to" + the basic verb form) or the verb with an "ed", "ing", "was" or "ing" ending. The answers are all in the Exercise Key.



DEACTIVATE (make inactive, stop, cut, isolate)
The wing anti-ice system is when the aircraft is on the ground.

DE-ENERGIZE (cut electrical power)
Overheat thermal protection condition exists.

DEPRESS (press, push, + DEPRESSURIZE)
N.B. "Depress" is the subject of the example sentence.

the LOGOS push-button tests the continuity of the detection loops.

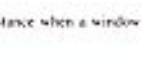
Illustrations to aid comprehension.



Important vocabulary and language items are glossed in an index at the back of the book.

Interactive reading approach.

After each group of modules there is a **Review section** with additional exercises and activities for consolidation and testing.

Space for trainees to complete information and write in their answers: the *Documentation Handbook* is a textbook, a reference book and a workbook.

27. To operate body. W S L

28. Sudden movement of fluid, air. S M

29. Small fragment existing from edge of part. S C

30. Detonation. P



of the words in both parts of Module 5 which refer to the illustrations on page 155. You have the first letter, the number of letters that follow, and the related system, etc. Number One has been done for you.



2. Door L

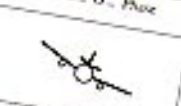

3. O... O... Phase



4. Aircraft B



5. The W



6. Door S



7. Brakes A

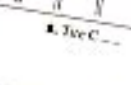

8. The C

155

Answers can be checked in the Exercise Key at the back of the book.

2. system maintenance

- The activities in the *System Maintenance* volume are graded by difficulty and type.

System Maintenance is an anthology of texts taken from a wide variety of documents on conventional and "glass cockpit" aircraft, in both standard and Simplified English.

The texts are grouped by ATA chapter (Flight Controls, Fuel, Pneumatics, Power Plant, etc.) and are combined with exercises.

Each text has a series of exercises to:

- develop language skills;
- assist vocabulary acquisition;
- teach reading strategies and techniques;
- ensure technical comprehension.

Extensive texts are taken from all types of aircraft maintenance documents and all aircraft systems.

A 320 AMM 32.31.00 P. 60



P. In-Line Check Valves (Ref. Fig. 632)

(1) General

There are five in-line check valves installed in the landing gear systems.

The check valves have a cylindrical body, made of stainless steel, which contains a poppet and a spring. These connections form hydraulic connections at each end. These connections have dimensions, which prevent incorrect installation of the valve. When the check valve is in the closed position, the contact between the poppet and the valve seat makes it impossible for the valve to leak.

When the pressure on the inlet side is more than that on the outlet side, the poppet opens against the spring compression. When the pressure on the outlet side is more than (or equal to) that on the inlet side, the spring compression keeps the poppet against the valve seat.

Landing Gear System - In-Line Check Valve.
Figure 632

142
FOR TRAINING PURPOSES ONLY

14 ATA 32 LANDING GEAR

GLOSSARY 32

Here is a glossary of some terms from the texts in ATA chapter 32. It is not complete, but explains some important words. You can add a translation in your own language.

ABBREVIATIONS	FAA, CAA, DGAC, etc.
AUTHORITIES	is contact with
AGAINST	resistance of metals
ALLOY	cylindrical part on which wheels are installed
AXLE	they make rotation easy
BEARINGS	close the verb "to break"
BROKEN	non return valve
CHECK VALVE	due to use again, to usage
DISCARD (v)	
END	

14 ATA 32 LANDING GEAR

1 Find the words in the description which refer to these definitions.

1. structure
2. a metal that cannot corrode
3. a mixture of metals
4. a flexible, helical coil part
5. extremity
6. stop, make impossible

2 * Read the text. Then decide if these sentences are true (correct) or false (incorrect). Don't forget to check your answers in the Exercise Key.**

1. The check valve body is tubular. TRUE FALSE
2. The poppet moves inside the body. TRUE FALSE
3. There are two unions on the valve. TRUE FALSE
4. The different size of the connections stops incorrect installation. TRUE FALSE
5. The spring opens the poppet when the upstream pressure is greater. TRUE FALSE
6. The inlet is larger than the outlet. TRUE FALSE
7. The spring is downstream of the poppet. TRUE FALSE
8. There are 4 check valves on the system. TRUE FALSE

3 * "METAL-TO-METAL" is a type of connection. There are many other double words. Find the double words which agree with these descriptions.**

1. joined by their extremities: --
2. facing each other: --
3. radio communications between 2 aircraft: --
4. radio communications between aircraft and ground: --
5. movement of radar antenna: --

143
FOR TRAINING PURPOSES ONLY

A system of cross-references enables constant interplay with the *Documentation Handbook*.

The answers at the end of the book facilitate self-access.